

**STERLING**  
*shapes*



by  
**STERLING**  
*surfaces*

**TR1585\_3\_STATION**

**TROUGH STYLE SINK WITH INFINITY DRAIN**

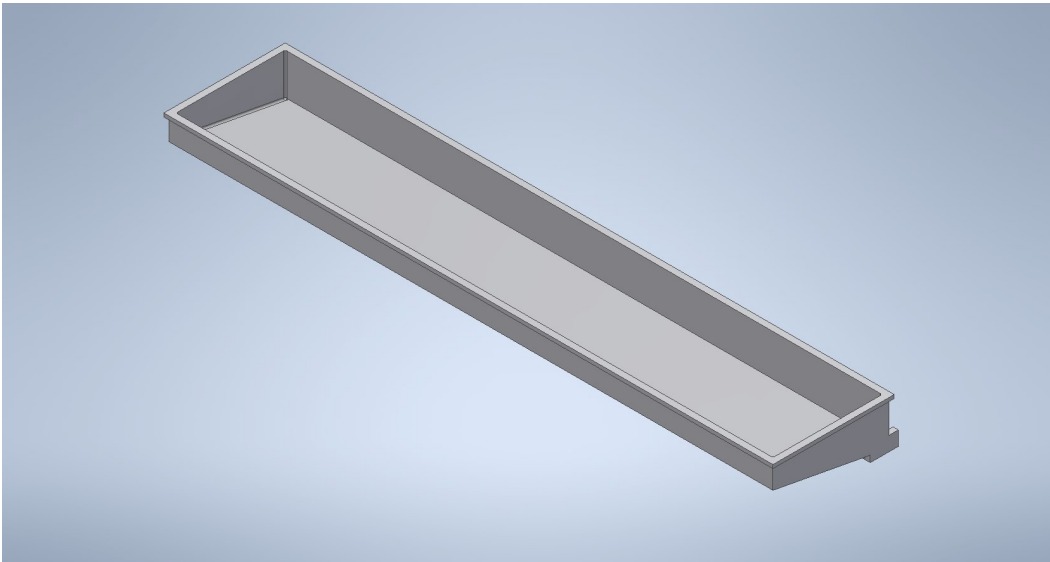

**Codes this Sink meets:**

UPC and ANSI compliant.

TESTED IN ACCORDANCE WITH THE APPROPRIATE  
SECTIONS OF THE CSA B45.5/IAPMO Z124 STANDARD



**Available Colors:**

All Solid Surface colors, including:

- Dupont Corian®
- Lg HI-MACS®
- Avonite Surfaces®
- KRION™ solid surface
- Wilsonart® solid surface
- Formica®

**What you get:**

Classic under-mount or drop in to quartz or stone tops  
& Solid Surface.

15 1/2" (393.7mm) x 85" (2159 mm) x 6" (152.4 mm)

180 grit final finish after mount by fabricator.

10-year material / 1 year fabrication warranty.

Convenient online ordering.

**Product Specification:**

Sterling Shapes Lavatory Trough style sink with infinity drain 15.5 " in width and 85" in length .  
Lavatory sink to be made of Solid surface Drop in or mounted below counter in a seamed under-  
mount application.

# TR1585\_3\_STATION

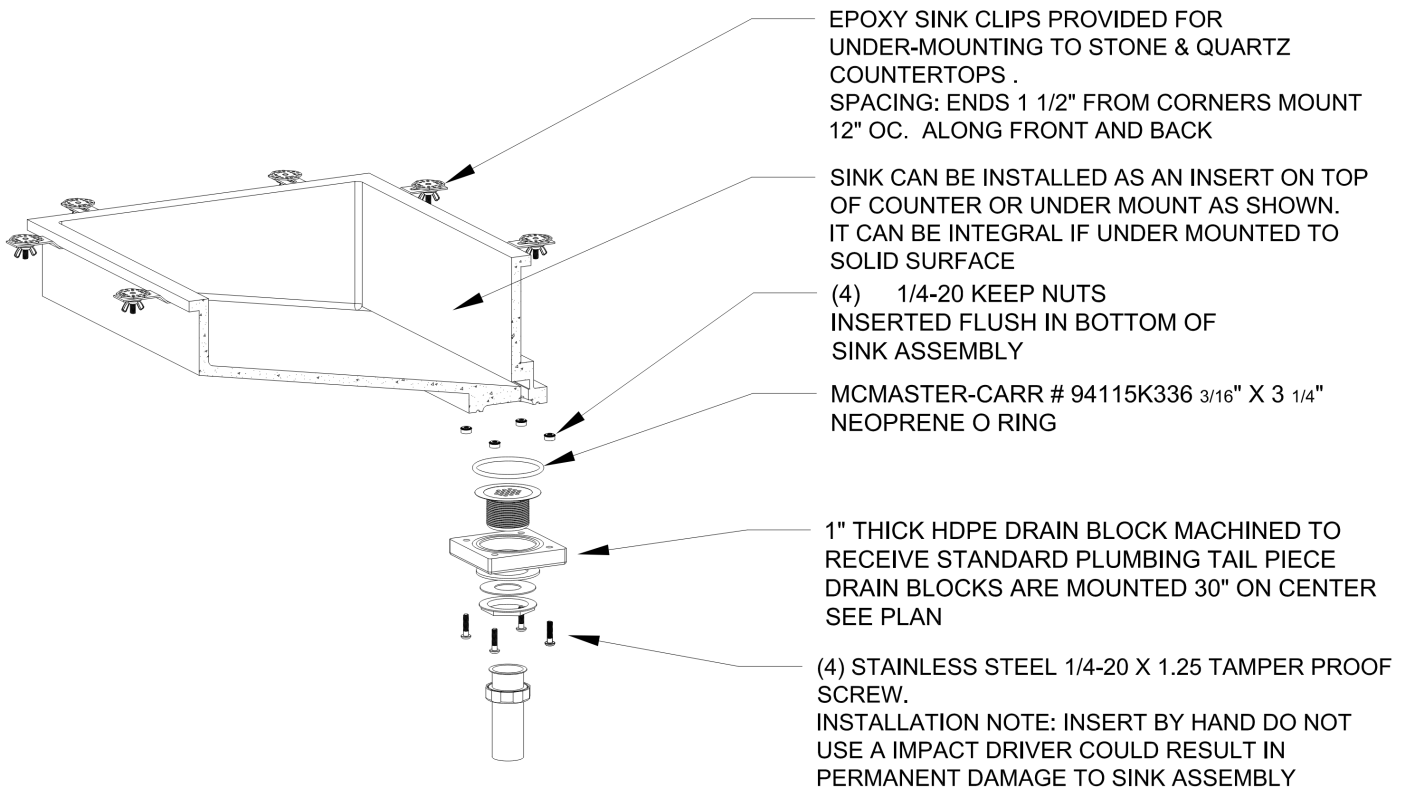
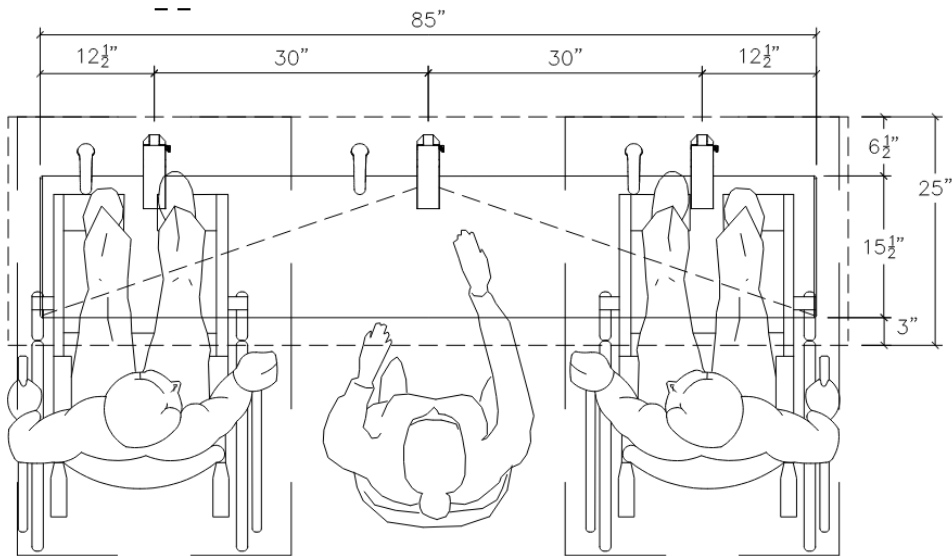



## *Sterling Shapes Care and Maintenance*

While *Sterling Shapes* Solid Surface is extremely tough and durable, like any fine material it can be damaged if abused or mistreated. Reviewing these care and cleaning instructions can assist you in understanding how easy it is to care for *Sterling Shapes* Solid Surface products and how you can prevent more severe damage that may require professional repairs.

**Normal Cleaning:** Our sinks and bowls are non-porous so they can be easily wiped clean with a damp cloth or sponge and mild detergents or general purpose cleaners. If you have a factory matte finish, abrasive cleaners may also be used. Periodically, it may also be helpful to go over the entire surface with an abrasive cleaner or a wet Scotch Brite\* pad to maintain a uniform appearance.

**Spills and Stains:** While most everyday spills can be removed with the cleaning techniques mentioned, some troublesome spills and stains such as food/hair dye, tea and fruit drinks may require more aggressive cleaning. These items can be removed with a solution of 50/50 bleach and water allowed to sit for 15 minutes, drained, and flushed with water. Follow with a general cleaner and flush with water. On factory matte finish, if you prefer, you can scrub with an abrasive cleanser.

**Cigarettes:** *Sterling Shapes* Solid Surface will not burn, but should a lighted cigarette accidentally come in contact with the surface it could leave a nicotine stain or a scorch mark. Either of these can be removed with an abrasive cleaner or buffing with a Scotch Brite\* pad.

**Some Simple Precautions:** **DO NOT** place hot pans directly from the burner or the oven into the solid surface sink or bowl. Even though the material can withstand sustained temperatures up to 225°F., prolonged or extreme heat could cause yellowing and/or cracking. **To prevent cracking due to extreme temperature differences, frozen foods should be placed on a mat or rack and not directly on the bottom of the sink to thaw.**

**DO NOT** use your sink for cutting or chopping items. Although minor cuts and scratches can be repaired, deep cuts will require the services of a professional, which is an extra expense.

**DO NOT** expose to extreme temperature fluctuations. **Boiling water should be drained into the sink with cool water running.** Rapid changes in water temperature may cause cracking, this includes thawing frozen items.

Strong acids such as those found in drain cleaners, toilet bowl and oven cleaners should be used cautiously around *Sterling Shapes* Solid Surfaces. If these items are accidentally spilled, wipe them up at once, flush with clear lukewarm water and wipe with a clean sponge.

**Repairing Scratches:** *Sterling Shapes* solid surface sinks and bowls are usually supplied with a matte finish (unless specified otherwise) which is equivalent to sanding with 320 grit sandpaper or buffing with a wet #7448 Scotch Brite\* pad. For removing superficial scratches use a wet Scotch Brite\* scouring pad, available in most supermarkets, until the scratches are removed. Clean thoroughly with soap and water. Note: Deep scratches can be removed by first carefully sanding lightly with 120 grit sandpaper followed by 220- 320 grit sandpaper. Then use a wet #7448 Scotch Brite\* pad to restore the finish. (Available from industrial supply houses) Gloss Finish (not recommended) For any damage, contact your fabricator/installer to repair.